

AMT RAIL TRAILERS

AMT Rail Trailers are designed to let you work as efficiently as possible. The compact low body and low weight allow you to maximise capacity utilisation. The robust frame, heavy-duty bearings and reliable brakes on all wheels ensure minimum maintenance.

All rail trailers are designed according to the statutory requirements in Europe EN 15954. The final construction takes place in accordance with the nationally applicable guidelines (e.g. TCVT, Infrabel, SNCF, TSA, BAV, EBA or DB).

All our vehicles are equipped with a well-proven braking system. This can be operated either hydraulically or with air.

AMT RAIL ROAD BV
Rithmeesterpark 11
4838 GZ Breda
Nederland

T +31 (0)76 501 5912
E info@amtgroup.nl
www.amtgroup.nl

SALES PARTNER:

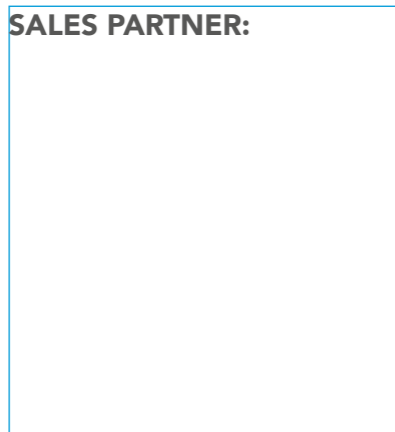

AMT ECOLINER

THE MULTI-PURPOSE TRAILER FOR ALL RAIL OPERATIONS

LOW IN HEIGHT

LIGHTWEIGHT

EXTRA STABLE

AMT ECOLINER

THE MULTI-PURPOSE TRAILER FOR ALL RAIL OPERATIONS

LOW IN HEIGHT

The loading surface of the AMT Ecoliner sits only 500 mm from the track.

LIGHT IN WEIGHT

The total weight of the AMT Ecoliner is:
- 2400 kg as a flatbed lorry
- 3200 kg as a container lorry (excluding middle bed).

EXTRA STABLE

The AMT Ecoliner is extra stable thanks to the new axle suspension

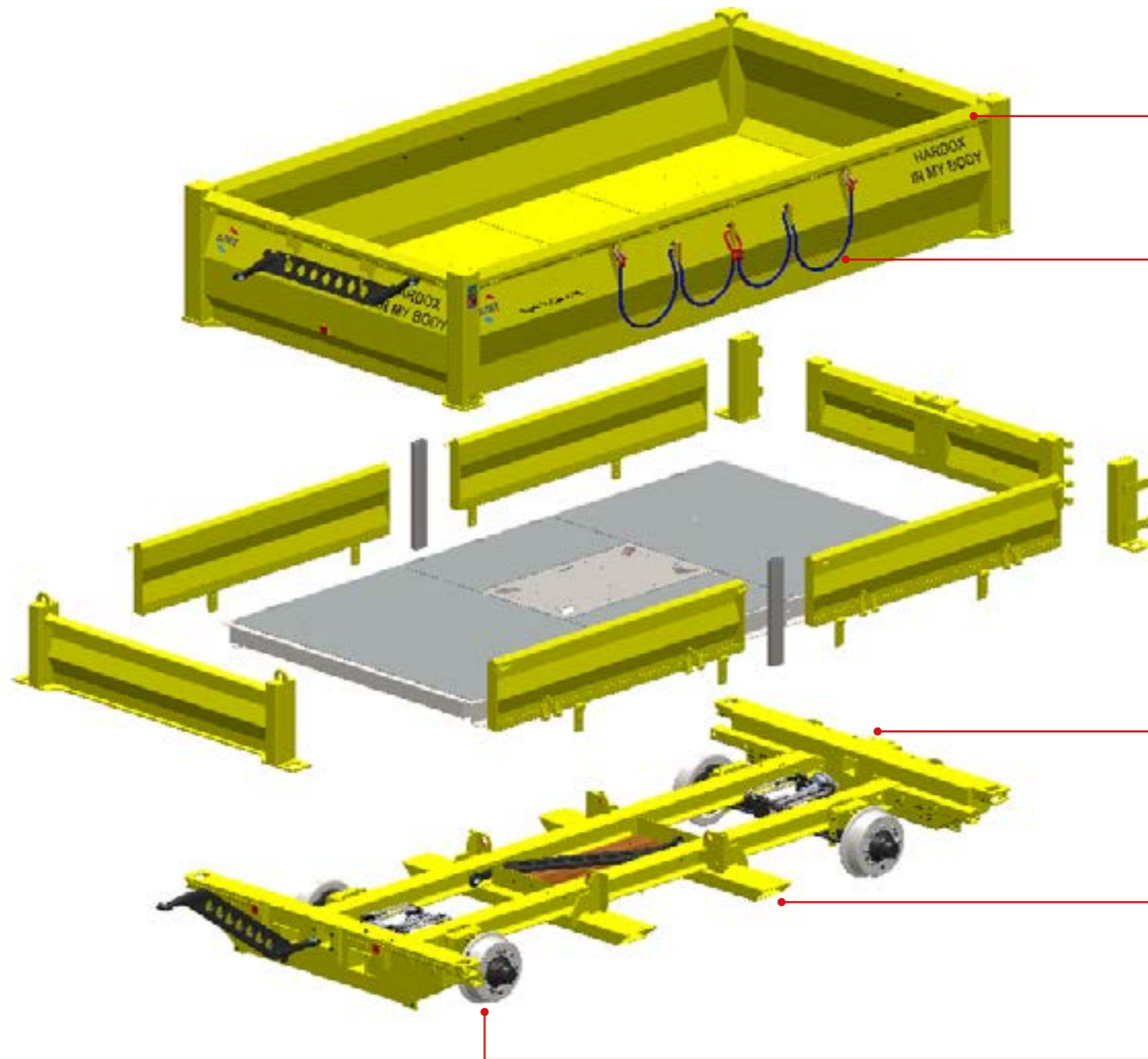

HARDOX
BOTTOM PLATES

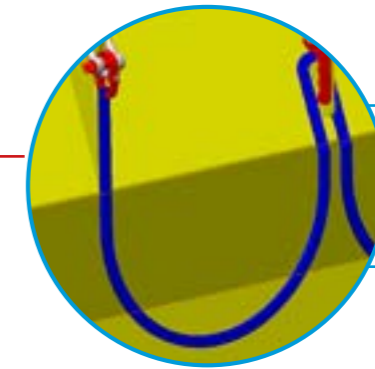

FIXED LIFTING
CHAINS

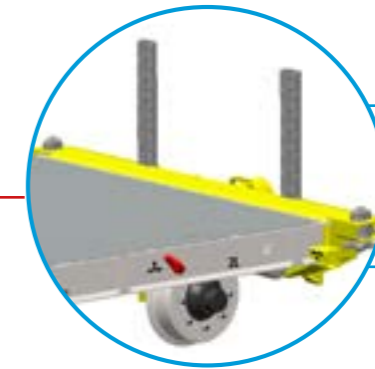

RUNG POSTS
(TO GUIDE CON-
TAINER)

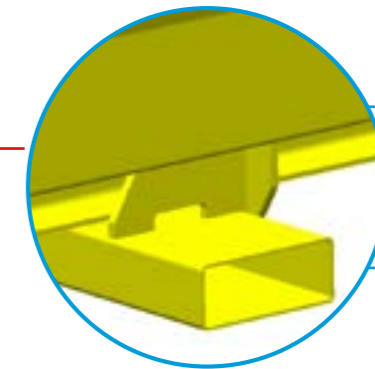

FORK LIFT HOLES

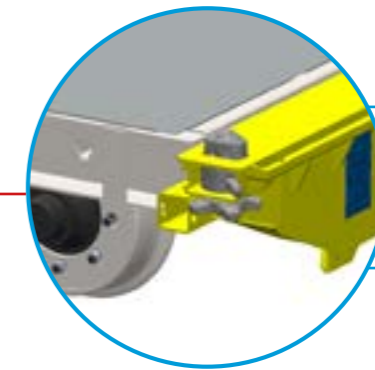

TWISTLOCKS

The multi-purpose AMT Ecoliner offers everything a rail contractor needs. The trailer is low in height, lightweight and robustly built. Multiple combinations are possible between frame, flatbed and container (with hardox).

